

18.95

60' WORKING HEIGHT

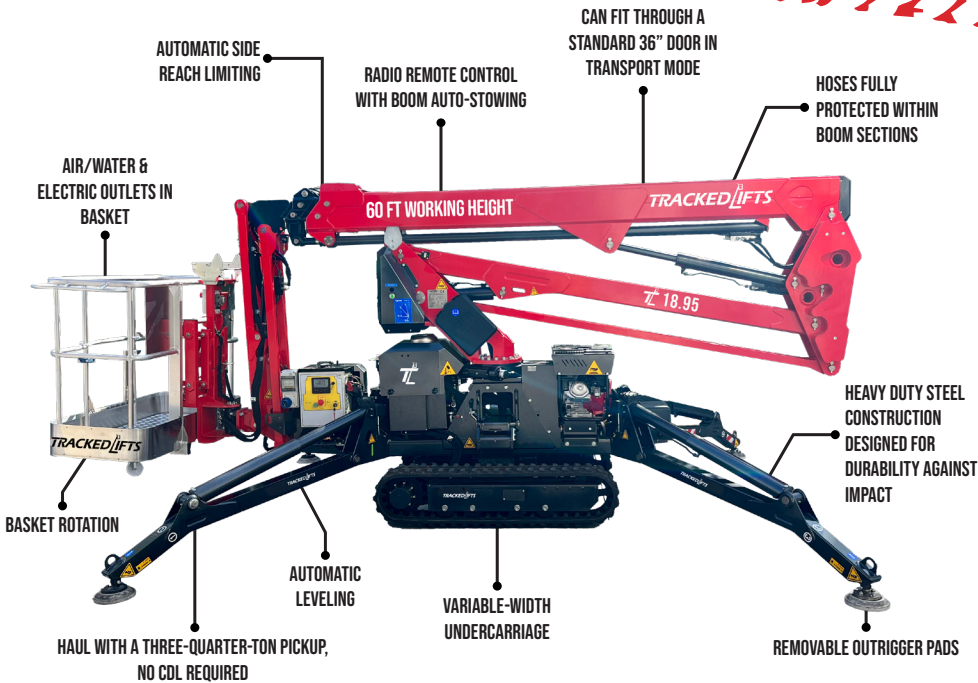

SPECIFICATIONS

Max. working height	60'
Max. outreach	31'5"
Max. basket load	507 lbs
Basket size	2'7" x 2'3" (1-man basket)
Basket rotation	± 90°
Turret rotation	360° non-continuous
Traveling length	14'3" (16'5" with basket)
Traveling height	6'6" narrow mode / 7'3" wide mode
Traveling width	2'7" narrow mode / 3'6" wide mode
Outrigger Spread	10'2" x 12'11"
Battery	110V Emergency Descent System
Gasoline Engine	Honda Gasoline, 13 HP
Total weight	5,600 lbs
Gradability, max. across slope	31% (17°)
Gradability, max. up and down slope	29% (16°)
Deployment ability on slopes up to	31% (17°)

DIAGRAMS

DATA AND DIMENSIONS ARE INDICATIVE AND NOT BINDING

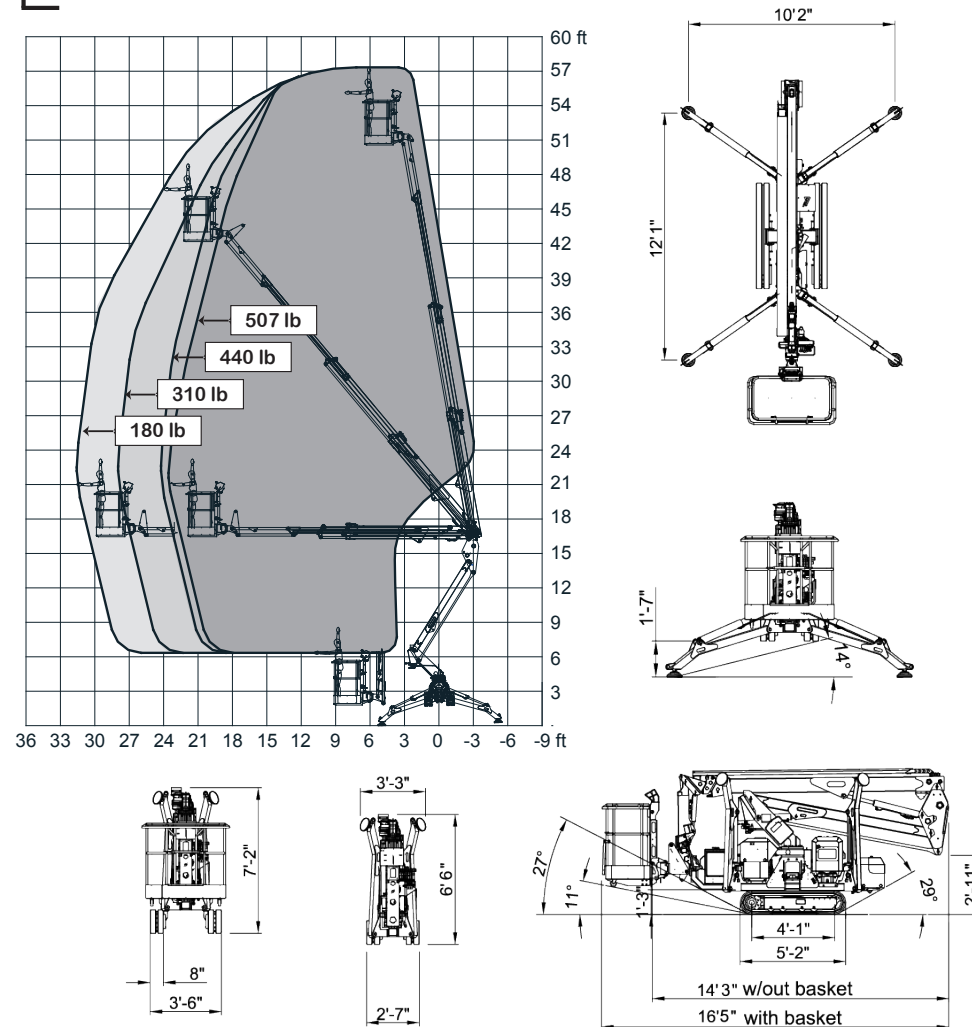

ADD-ON OPTIONS:

- White Rubber Non-Marking Tracks
- Custom Colors
- 2-man Basket
- Kubota Diesel
- Kubota Diesel + 24V Battery Hybrid
- Emergency 12V Hydraulic System
- Lithium Ion Battery Pack
- 2 Speed Drive Motors
- Increased Size of Foot Plates (13.75" Diameter)